



Since 1996

Quality

Creativity

Stability



The company was founded in 1996 as Wingshing Industrial Ltd.



The new Demass brand for the professional market was launched in 2006.

## Profile

---

The Company was founded in 1996 and specialized in manufacturing measuring tape. With 20 years' efforts, it has expanded its operation to be a leading manufacturer of premium quality measuring tapes.

We are proud of our reputation for excellence, innovation and dedicated to testing, designing and improving our products to ensure quality on materials, shapes, functions and accuracy. Becoming the world's best at what we do is our lifelong goal.

The company continuously offers private label service for global hand tool industry, while also providing OEM service for major measuring tape manufacturers.

---

### Evolution

1996 Company was founded

1999 ISO9001 certification

2006 DEMASS brand was launched

2008 EC and MID certification by NMRO UK

2011 MID certification by LNE France

2012 JIS certification by KSA Korea

2015 Two-side class I accuracy printing machine was imported from Japan

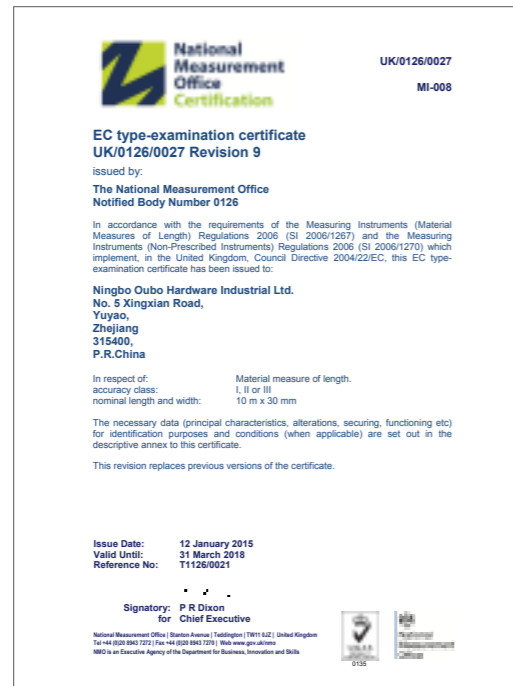

# Certificate

## EC

Demass measuring tapes have passed EC Type Approval which covers all member countries of the European Union. Our EC Type -Examination Certificate covers the following Demass measuring tapes:

Pocket tape	1m-10m	Class I or Class II
Long steel tape	10m-50m	Class II
Fiberglass tape	10m-50m	Class II or Class III

## Accuracy tolerance

- I**  $\pm [(0.1 + 0.1L) \text{ mm} + 0.1 \text{ mm}]$  (With hook)
- II**  $\pm [(0.3 + 0.2L) \text{ mm} + 0.2 \text{ mm}]$  (With hook)
- III**  $\pm [(0.6 + 0.4L) \text{ mm} + 0.3 \text{ mm}]$  (With hook)

Size	<b>I</b>		<b>II</b>	
	Tolerance (mm)	Tolerance with hook (mm)	Tolerance (mm)	Tolerance with hook (mm)
1m	$\pm 0.2$	$\pm 0.3$	$\pm 0.5$	$\pm 0.7$
2m	$\pm 0.3$	$\pm 0.4$	$\pm 0.7$	$\pm 0.9$
3m	$\pm 0.4$	$\pm 0.5$	$\pm 0.9$	$\pm 1.1$
5m	$\pm 0.6$	$\pm 0.7$	$\pm 1.3$	$\pm 1.5$
8m	$\pm 0.9$	$\pm 1$	$\pm 1.9$	$\pm 2.1$
10m	$\pm 1.1$	$\pm 1.2$	$\pm 2.3$	$\pm 2.5$

Pocket tape

Size	<b>II</b>		<b>III</b>	
	Tolerance (mm)	Tolerance with hook (mm)	Tolerance (mm)	Tolerance with hook (mm)
10m	$\pm 2.3$	$\pm 2.5$	$\pm 4.6$	$\pm 4.9$
15m	$\pm 3.3$	$\pm 3.5$	$\pm 6.6$	$\pm 6.9$
20m	$\pm 4.3$	$\pm 4.5$	$\pm 8.6$	$\pm 8.9$
30m	$\pm 6.3$	$\pm 6.5$	$\pm 12.6$	$\pm 12.9$
50m	$\pm 10.3$	$\pm 10.5$	$\pm 20.6$	$\pm 20.9$
100m	$\pm 20.3$	$\pm 20.5$	$\pm 40.6$	$\pm 40.9$

Long tape



UK

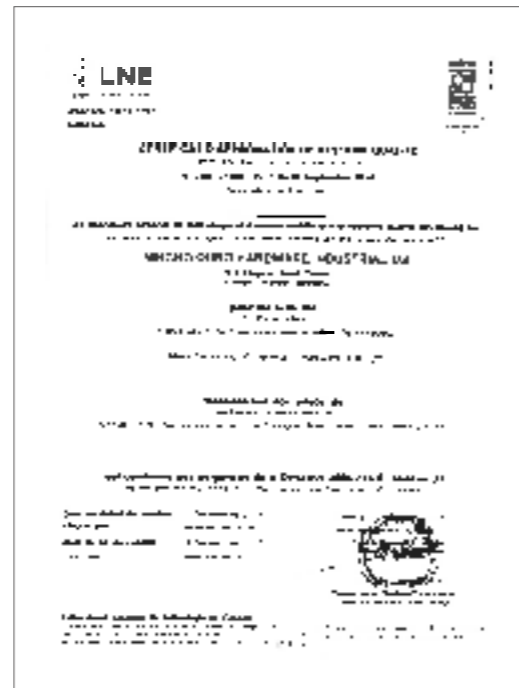

France

# Certificate

## MID

Demass products are in conformity with the essential requirements of the “Measuring Instruments Directive 2004/22/EC of the European Parliament and of the Council on Measuring Instruments” as well as the special requirements under Annex MI-008 material measures for Class I and Class II accuracy.

## MID standard blade

- ▲ Total length
- ▲ Class of accuracy
- ▲ Conformance Européenne
- ▲ Year of manufacturing
- ▲ Code of notify body
- ▲ Mark of manufacturer
- ▲ Number of EC-type certificate



Metric

UK



Metric

France



Metric / Inch

UK

# Certificate



**JIS** DEMASSのコンベックスはJIS規格の審査に合格(審査内容は規定の基準と品質管理システム)。製品テープの精度は表・裏面ともにJIS1級です。

- ▲ JISマーク
- ▲ 製品名
- ▲ 製造工場マーク
- ▲ 審査機関マーク
- ▲ 精度クラス
- ▲ 証書番号
- ▲ 製品種類番号
- ▲ 全長
- ▲ 製造工場マーク

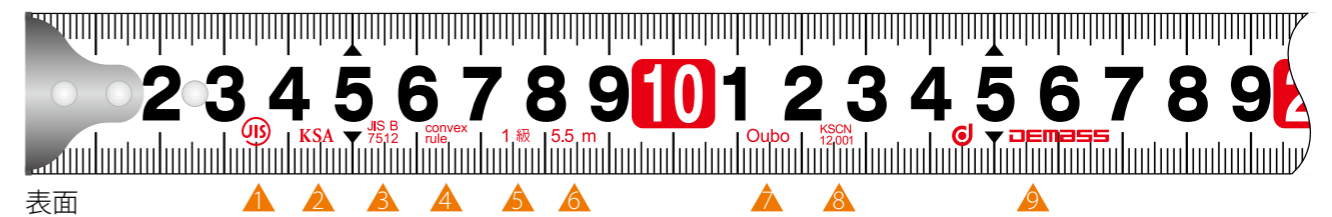

## 精度公差

**1級** ± [(0.2 + 0.1L) mm + 0.2 mm] (ツメ含む)

仕様	公差許容範囲 (mm)	公差許容範囲 (ツメ含む)(mm)
1m	± 0.3	± 0.5
2m	± 0.4	± 0.6
3.5m	± 0.6	± 0.8
5.5m	± 0.8	± 1
8m	± 1	± 1.2
10m	± 1.2	± 1.4

# Index



AUTO BRAKE  
14 - 15



COMPRESS  
16 - 17



iTape  
18 - 19



bTape  
20 - 21



AUTO LOCK  
22 - 23



RUBBER PRO  
24 - 25



PULL-LOCK  
26 - 27

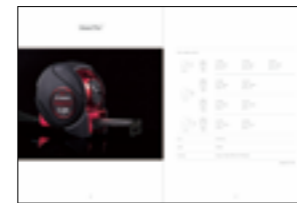

ASIAN PRO  
28 - 29



JACKET PRO  
30 - 31



GRIP CHROME  
32 - 33



RUBBER SATIN  
34 - 35



PROFESSIONAL TAPE  
36 - 37



ASIANIZATION  
38 - 39



GRIP GEAR  
40 - 41



GEAR FRAME  
42 - 43



Referential Tape  
Belt Tape Holder  
44 - 45



Main material  
46 - 47



Blade layout  
48 - 49



Blade finish  
Blade color  
50 - 51



Bi-color coating and  
two-side printing  
Five-color printing  
52 - 53



Reference of end hook  
54 - 55



Blade stand-out  
Blister card  
56 - 57

**Auto Brake™**



Item number and size

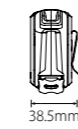
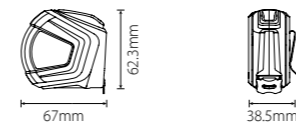

RU 2019  
2m × 19mm  
6ft × 3/4"

RU 3019  
3m × 19mm  
10ft × 3/4"

RU 3519  
3.5m × 19mm  
12ft × 3/4"

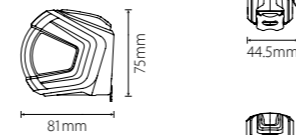

RU 5022  
5m × 22mm  
16ft × 7/8"

RU 5522  
5.5m × 22mm  
18ft × 7/8"

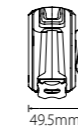

RU 5027  
5m × 27mm  
16ft × 1 1/16"

RU 5527  
5.5m × 27mm  
18ft × 1 1/16"

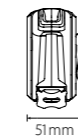
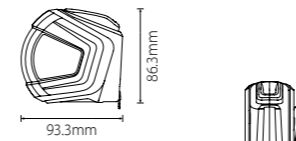

RU 7527  
7.5m × 27mm  
25ft × 1 1/16"

RU 8027  
8m × 27mm  
26ft × 1 1/16"

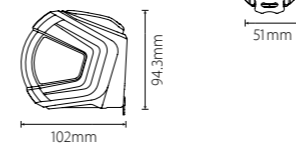

RU 9027  
9m × 27mm  
30ft × 1 1/16"

RU 10027  
10m × 27mm  
33ft × 1 1/16"

Lock Auto lock

Label Rubber

Housing ABS with TPR covered with painted parts

*Designed in 2014*



COMPRESS™



Item number and size

		RW 2016 2m × 16mm 6ft × 5/8"	RW 3016 3m × 16mm 10ft × 5/8"	RW 3516 3.5m × 16mm 12ft × 5/8"
		RW 5019 5m × 19mm 16ft × 3/4"	RW 5519 5.5m × 19mm 18ft × 3/4"	
		RW 5025 5m × 25mm 16ft × 1"	RW 5525 5.5m × 25mm 18ft × 1"	
		RW 7525 7.5m × 25mm 25ft × 1"	RW 8025 8m × 25mm 26ft × 1"	

Lock Push lock

Label Hot stamping

Housing ABS with TPR

Designed in 2015

# iTape



---

Item number and size

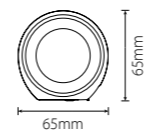

PG 3013  
3m × 13mm  
10ft × 1/2"

PG 3513  
3.5m × 13mm  
12ft × 1/2"

---

Lock

Auto lock

---

Label

Printing

---

Housing

Painted ABS with chrome-plated ring covered with rubber parts

---

*Designed in 2013*

# bTape



## Item number and size

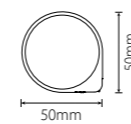

PL 2009  
2m x 9mm  
6ft x 3/8"

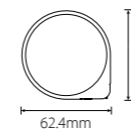

PL 3013  
3m x 13mm  
10ft x 1/2"

PL 3513  
3.5m x 13mm  
12ft x 1/2"

Lock

Auto lock

Label

Printing

Housing

ABS with TPR covered with painted label parts

**Auto Lock™**



Item number and size

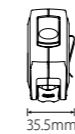
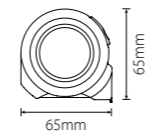

TD 2016  
2m × 16mm  
6ft × 5/8"

TD 3016  
3m × 16mm  
10ft × 5/8"

TD 3516  
3.5m × 16mm  
12ft × 5/8"

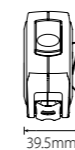
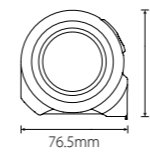

TD 5019  
5m × 19mm  
16ft × 3/4"

TD 5519  
5.5m × 19mm  
18ft × 3/4"

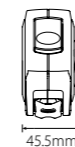

TD 5025  
5m × 25mm  
16ft × 1"

TD 5525  
5.5m × 25mm  
18ft × 1"

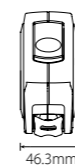
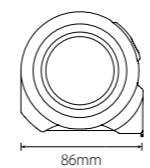

TD 7525  
7.5m × 25mm  
25ft × 1"

TD 8025  
8m × 25mm  
26ft × 1"

Lock Auto lock

Label Acrylic

Housing ABS with vacuum filmed ring

*Designed in 2013*



Item number and size

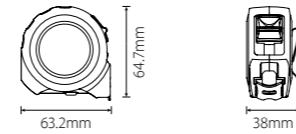

RJ 2019  
2m × 19mm  
6ft × 3/4"

RJ 3019  
3m × 19mm  
10ft × 3/4"

RJ 3519  
3.5m × 19mm  
12ft × 3/4"

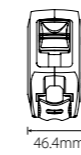
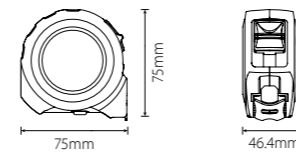

RJ 5025  
5m × 25mm  
16ft × 1"

RJ 5525  
5.5m × 25mm  
18ft × 1"

RJ 5027  
5m × 27mm  
16ft × 1 1/16"

RJ 5527  
5.5m × 27mm  
18ft × 1 1/16"

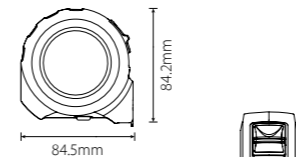

RJ 7527  
7.5m × 27mm  
25ft × 1 1/16"

RJ 8027  
8m × 27mm  
26ft × 1 1/16"

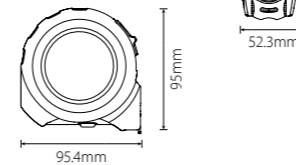

RJ 9027  
9m × 27mm  
30ft × 1 1/16"

RJ 10027  
10m × 27mm  
33ft × 1 1/16"

Lock

Push lock and bottom stop

Label

Aluminium or Rubber

Housing

Vacuum filmed ABS with TPR

Designed in 2011



Item number and size

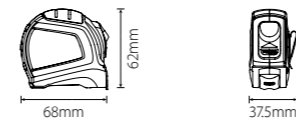

RE 2016  
2m x 16mm  
6ft x 5/8"



RE 3016  
3m x 16mm  
10ft x 5/8"

RE 3516  
3.5m x 16mm  
12ft x 5/8"



RE 5019  
5m x 19mm  
16ft x 3/4"



RE 5519  
5.5m x 19mm  
18ft x 3/4"



RE 5025  
5m x 25mm  
16ft x 1"

RE 5525  
5.5m x 25mm  
18ft x 1"

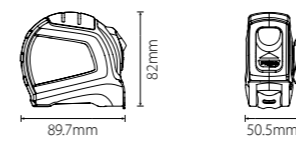

RE 7525  
7.5m x 25mm  
25ft x 1"

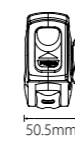

RE 8025  
8m x 25mm  
26ft x 1"

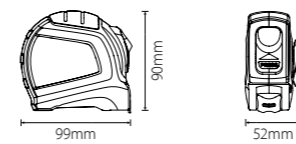

RE 9025  
9m x 25mm  
30ft x 1"

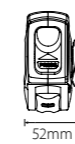

RE 10025  
10m x 25mm  
33ft x 1"

Lock Auto lock

Label Rubber

Housing Painted ABS with TPR

*Designed in 2009*



Item number and size

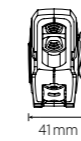
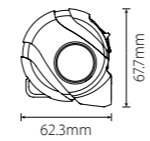

JX 2016  
2m × 16mm  
6ft × 5/8"

JX 3016  
3m × 16mm  
10ft × 5/8"

JX 3516  
3.5m × 16mm  
12ft × 5/8"

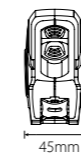
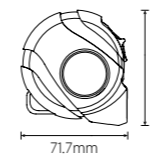

JX 5019  
5m × 19mm  
16ft × 3/4"

JX 5519  
5.5m × 19mm  
18ft × 3/4"

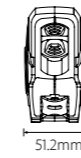

JX 5025  
5m × 25mm  
16ft × 1"

JX 5525  
5.5m × 25mm  
18ft × 1"

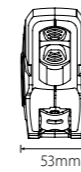
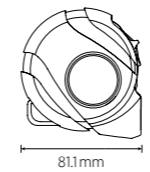

JX 7525  
7.5m × 25mm  
25ft × 1"

JX 8025  
8m × 25mm  
26ft × 1"

Lock

Push lock

Label

Rubber

Housing

Vacuum filmed ABS with TPR jacket

Designed in 2012

JACKET PRO™



Item number and size

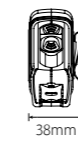
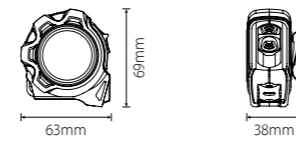

JY 2016  
2m x 16mm  
6ft x 5/8"

JY 3016  
3m x 16mm  
10ft x 5/8"

JY 3516  
3.5m x 16mm  
12ft x 5/8"

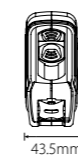
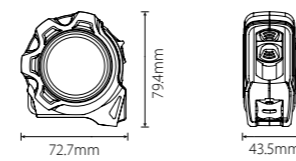

JY 5019  
5m x 19mm  
16ft x 3/4"

JY 5519  
5.5m x 19mm  
18ft x 3/4"

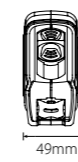
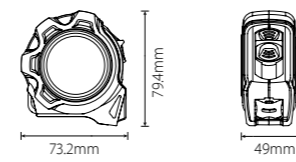

JY 5025  
5m x 25mm  
16ft x 1"

JY 5525  
5.5m x 25mm  
18ft x 1"

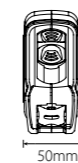
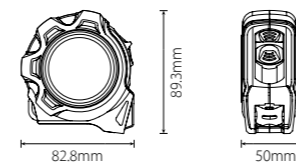

JY 7525  
7.5m x 25mm  
25ft x 1"

JY 8025  
8m x 25mm  
26ft x 1"

Lock Push lock

Label Rubber

Housing Vacuum filmed ABS with TPR jacket

Designed in 2013



# GRIP CHROME™

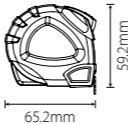
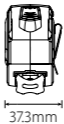
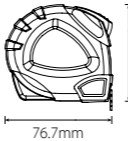
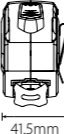
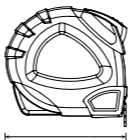
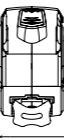

## Item number and size

		RB 2016 2m × 16mm 6ft × 5/8"	RB 3016 3m × 16mm 10ft × 5/8"	RB 3516 3.5m × 16mm 12ft × 5/8"
		RB 5019 5m × 19mm 16ft × 3/4"	RB 5519 5.5m × 19mm 18ft × 3/4"	
		RB 5025 5m × 25mm 16ft × 1"	RB 5525 5.5m × 25mm 18ft × 1"	
		RB 7525 7.5m × 25mm 25ft × 1"	RB 8025 8m × 25mm 26ft × 1"	

Lock	Tight lock
Label	Moulded or rubber
Housing	ABS with TPR covered with chrome-plated part

*Designed in 2007*

# RUBBER SATIN™



## Item number and size

		RA 2016 2m × 16mm 6ft × 5/8"	RA 3016 3m × 16mm 10ft × 5/8"	RA 3516 3.5m × 16mm 12ft × 5/8"
		RA 5019 5m × 19mm 16ft × 3/4"	RA 5519 5.5m × 19mm 18ft × 3/4"	
		RA 5025 5m × 25mm 16ft × 1"	RA 5525 5.5m × 25mm 18ft × 1"	
		RA 7525 7.5m × 25mm 25ft × 1"	RA 8025 8m × 25mm 26ft × 1"	
		RA 10030 10m × 30mm 33ft × 1 3/16"		

Lock	Push lock
Label	Rubber
Housing	Painted ABS with TPR

Designed in 2006

**PROFESSIONAL TAPE™**



Item number and size

		TM 2016 2m × 16mm 6ft × 5/8"	TM 3016 3m × 16mm 10ft × 5/8"	TM 3516 3.5m × 16mm 12ft × 5/8"
		TM 5019 5m × 19mm 16ft × 3/4"	TM 5519 5.5m × 19mm 18ft × 3/4"	
		TM 5025 5m × 25mm 16ft × 1"	TM 5525 5.5m × 25mm 18ft × 1"	
		TM 7525 7.5m × 25mm 25ft × 1"	TM 8025 8m × 25mm 26ft × 1"	
		TM 9025 9m × 25mm 30ft × 1"	TM 10025 10m × 25mm 33ft × 1"	

Lock Push lock

Label PVC

Housing Painted ABS

*Designed in 2008*

# ASIANIZATION™



## Item number and size

		TX 2016 2m × 16mm 6ft × 5/8"	TX 3016 3m × 16mm 10ft × 5/8"	TX 3516 3.5m × 16mm 12ft × 5/8"
		TX 5019 5m × 19mm 16ft × 3/4"	TX 5519 5.5m × 19mm 18ft × 3/4"	
		TX 5025 5m × 25mm 16ft × 1"	TX 5525 5.5m × 25mm 18ft × 1"	
		TX 7525 7.5m × 25mm 25ft × 1"	TX 8025 8m × 25mm 26ft × 1"	
		TX 9025 9m × 25mm 30ft × 1"	TX 10025 10m × 25mm 33ft × 1"	

Lock Push lock

Label PVC

Housing ABS with chrome-plated ring

*Designed in 2010*

**GRIP GEAR™** – Long steel tape  
– Fiberglass tape



Item number and size

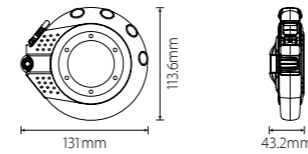

Long steel tape  
GG 1013  
10m × 13mm  
33ft × 1/2"

Long steel tape  
GG 2013  
20m × 13mm  
66ft × 1/2"

Long steel tape  
GG 3013  
30m × 13mm  
100ft × 1/2"

Fiberglass tape  
FGG 1015  
10m × 15mm  
33ft × 19/32"

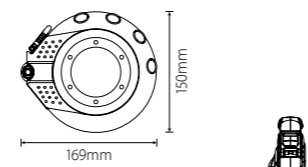

Long steel tape  
GG 5013  
50m × 13mm  
165ft × 1/2"

Fiberglass tape  
FGG 2015  
20m × 15mm  
66ft × 19/32"

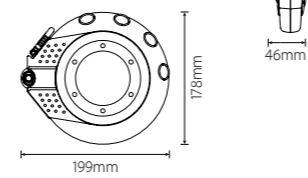

Fiberglass tape  
FGG 3015  
30m × 15mm  
100ft × 19/32"

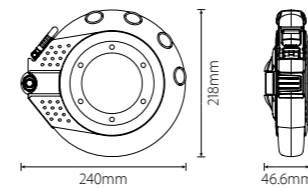

Fiberglass tape  
FGG 5015  
50m × 15mm  
165ft × 19/32"

Speed	3-time
Label	Rubber
Housing	Painted ABS with TPR

*Designed in 2008*

**GEAR FRAME™** – Long steel tape  
– Fiberglass tape



Item number and size

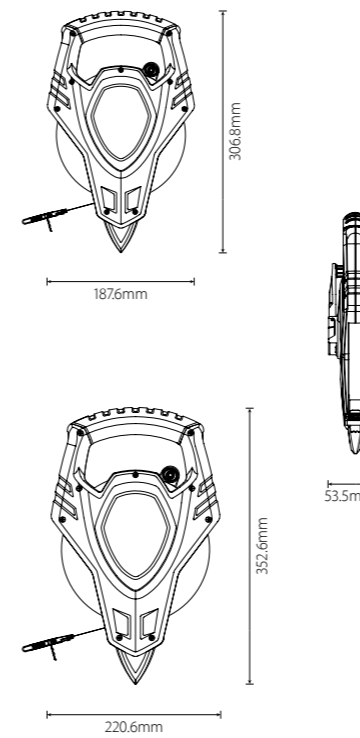

Long steel tape  
LWX 3013  
30m × 13mm  
100ft × 1/2"

Long steel tape  
LWX 5013  
50m × 13mm  
165ft × 1/2"

Fiberglass tape  
FWX 3015  
30m × 15mm  
100ft × 19/32"

Long steel tape  
LWX 10013  
100m × 13mm  
330ft × 1/2"

Fiberglass tape  
FWX 5015  
50m × 15mm  
165ft × 19/32"

Speed	3-time
Label	Rubber
Housing	Painted ABS with TPR

*Designed in 2009*

## Referential Tape

### 特長:

1. 粘着テープ付13mm幅のメジャーテープ
2. スチール製SK4
3. 精度公差  $\pm(0.2+0.1L)$ mm

### 用途:

ワークテーブルや機械等に貼って物指しとして使用できます。



### 使用方法:

1. テープ両端には釘等を打ち込んで仮止めできる2mmサイズの穴が付いています。
2. 裏面剥離紙は簡単に剥がすことができます。
3. テープはハサミでカットできます。

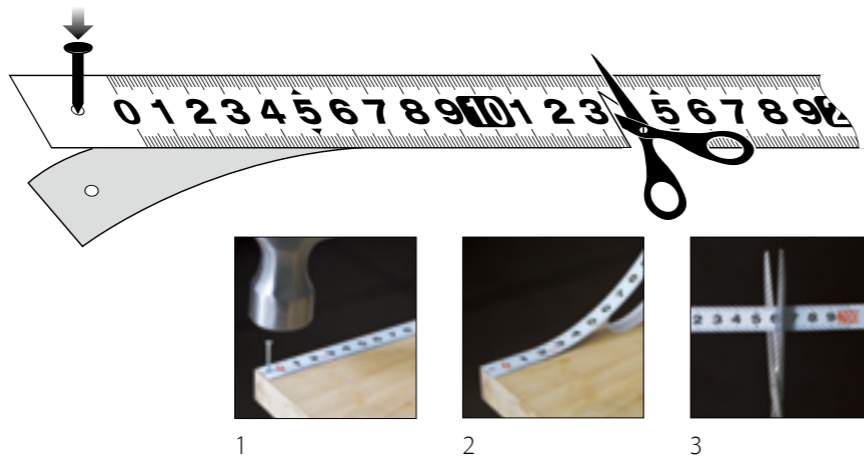

品番	規格
	長さ / 幅
CD 1013	1m / 13mm
CD 2013	2m / 13mm
CD 5013	5m / 13mm

## Belt Tape Holder

### 用途:

コンベックスの着脱を簡便化。



### 取付け、使用方法:

1. ドライバーでベルトクリップをはずしてください。付属のネジで、ベルトホルダーのアダプターを確実に締め込みます。
2. コンベックスホルダーをベルトに挿し込みます。
3. 専門アタッチメントを取付けたコンベックスを、カチャッと音がするまでホルダーに挿し込みます。
4. コンベックスを押さえホルダー上のボタンを親指で外向きに押しながら、コンベックスを上引き出します。

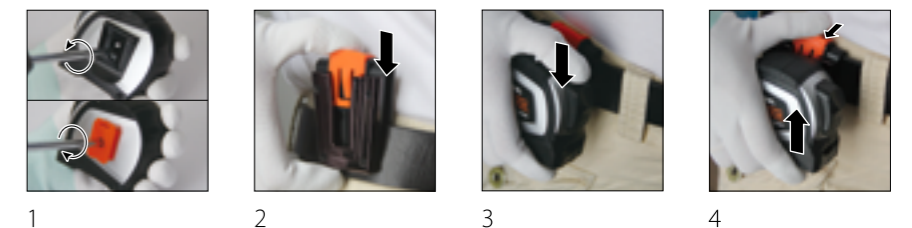

品番
PDJ-01

# Main material

## Blade

Mainly high carbon steel C60, SK4 and stainless steel SUS420. SK4 for JIS steel measuring tape only and SUS420 for stainless steel tape only.

Specification	C	Si	Mn	Cr	Ni
C60	0.57-0.65	0.17-0.37	0.5-0.8		
SK4	0.9-1.0	0.35	0.5		
SUS420	0.15-0.35	1.0	1.0	11.5-14.5	3.0

## Spring

High carbon steel 65Mn, SK4 and stainless steel SUS301. SK4 for JIS steel measuring tape only and SUS301 for stainless steel tape only.

Specification	C	Si	Mn	Cr	Ni
65Mn	0.62-0.7	0.17-0.37	0.9-1.2		
SK4	0.9-1.0	0.35	0.5		
SUS301	0.15	1.0	2.0	16.0-18.0	6.0-8.0



## End hook and belt clip

High carbon steel Q235, 65Mn and stainless steel SUS304. Q235 for end hook, 65Mn for belt clip and SUS304 for stainless steel tape respectively.

Specification	C	Si	Mn	Cr	Ni
Q235	0.12-0.2	0.3	0.3-0.7		
65Mn	0.62-0.7	0.17-0.37	0.9-1.2		
SUS304	0.07	1.0	2.0	17.0-19.0	8.0-11.0

## Housing and stop button

High performance ABS with TPR for housing and POM or ABS/PC with TPR for stop button.

ABS	 <b>LG</b>	TPR	<b>PROFLEX™</b>
POM	 <b>BASF</b>	ABS/PC	 <b>LG</b>



# Blade layout

## 1. Pocket tape blade

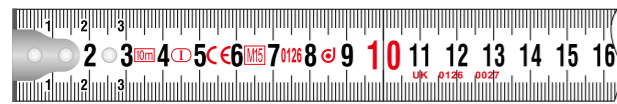

Metric MID scale

Front side



Back side



Metric JIS scale

Front side



Back side

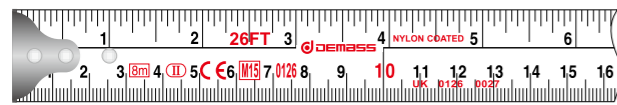

Metric / Inch MID scale

Front side



Back side

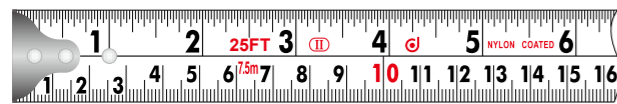

Metric / Inch scale

Front side

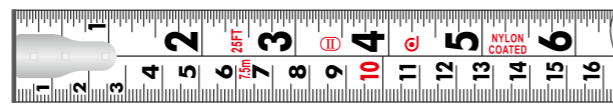

Back side

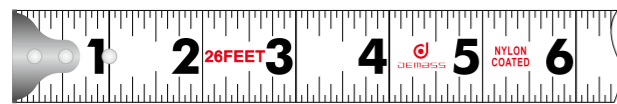

Inch standard scale

Front side

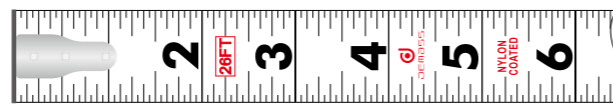

Back side

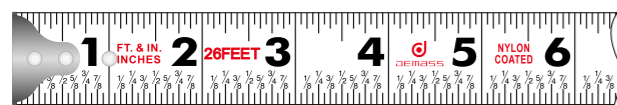

Inch easy-read scale

Front side

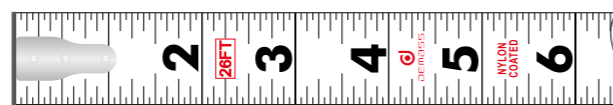

Back side



Chi / Metric scale

Front side



Back side

## 2. Long steel tape blade

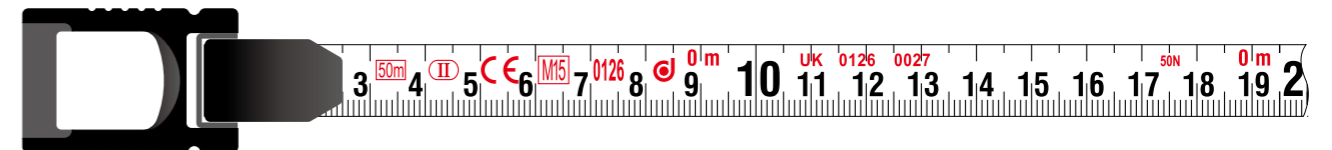

Metric scale

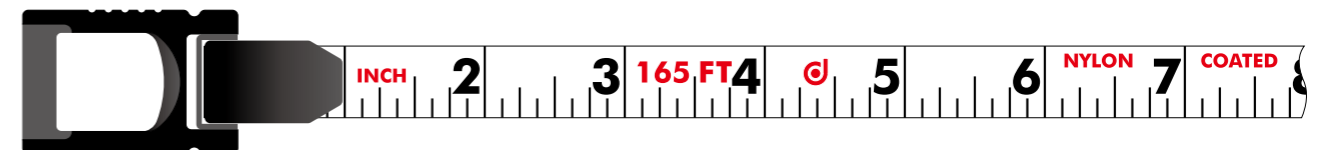

Inch scale

## 3. Fiberglass tape blade

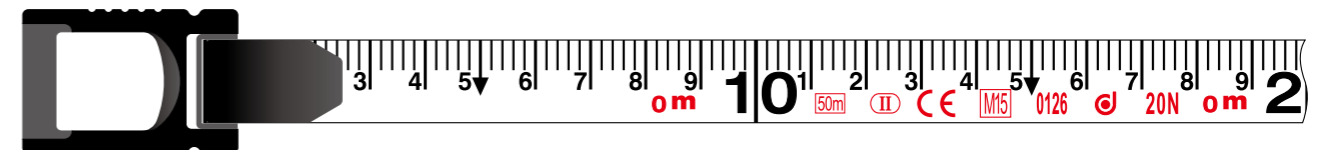

Metric 2mm scale

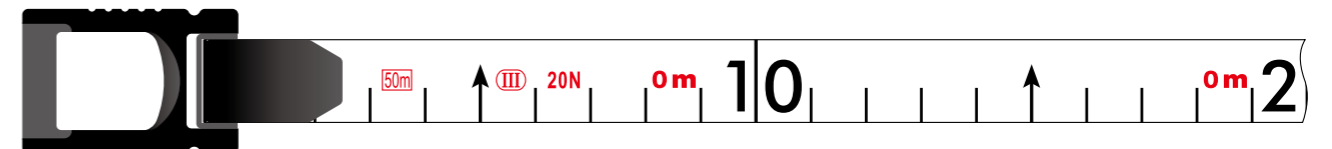

Metric 10mm scale

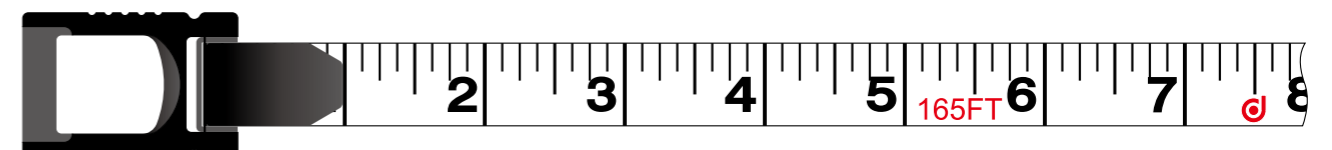

Inch scale

# Blade finish

## 1. Lacquered blade

By a special process, the high-quality environmental friendly water dissolved resin coating materials are evenly coated on the surface of the blade to protect the printed marks. There are bright and matte colors for choice.

## 2. Nylon coated blade

Combined with a high performance nylon and special coating process, the nylon coating covers the entire blade surface ensuring its abrasion resistance, anti-corrosion and prolonging its durability.

## 3. SUPERBLADE

Applied with a special extruding process, the high performance nylon thoroughly covers the whole blade to provide it with super abrasion resistance and the anti-corrosion functions like rust-proof, anti-acid, anti-alkali as well as to prolong its life.

### Technical specifications comparison

Specifications	The thickness of the coating layer (mm)	The abrasion resistance test with rubber (times)	The abrasion resistance test with falling sand (litres)
Lacquered blade	0.02	80	8
Nylon coated blade	0.03	300	20
Super blade	0.08	3000	150

# Blade color

High-quality environmental friendly water dissolved resin coating materials are applied on the blade with options of traditional white and yellow, and more fashionable fluorescence and silver colors, all coating materials meet the basic requirements of PAHs and REACH.

White

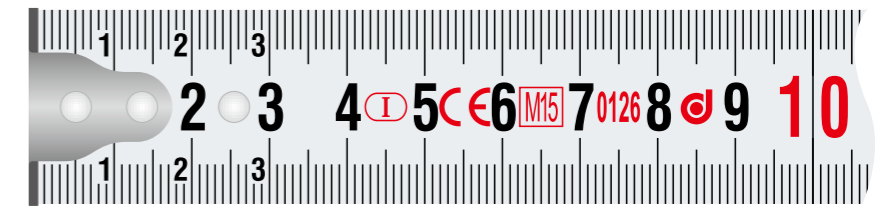

Yellow

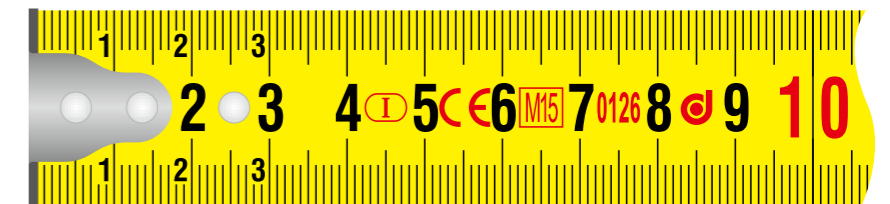

Fluorescence

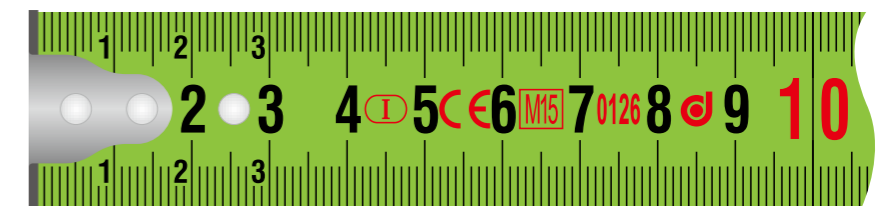

Silver

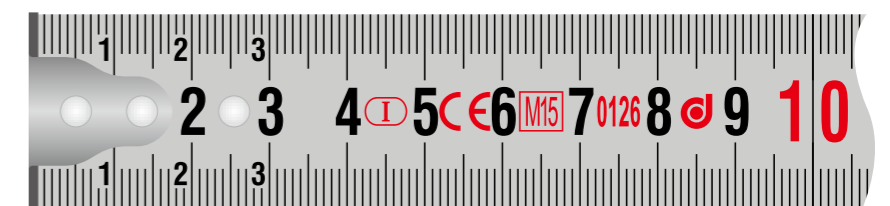

# Bi-color coating and two-side printing

1. Easy recognition with different color on different side
2. Same scale on both sides or different scale on different side.

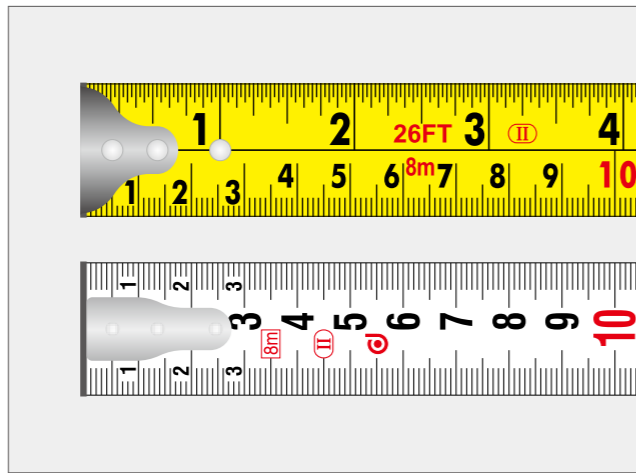

# Five-color printing

Black, blue and red on front surface, while black and red on back surface.

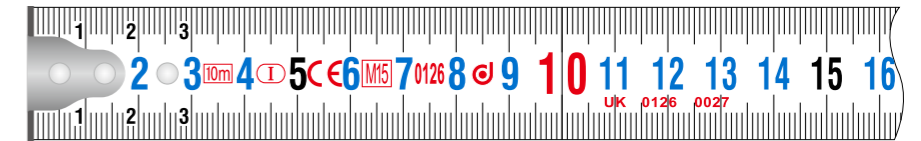

Metric MID scale

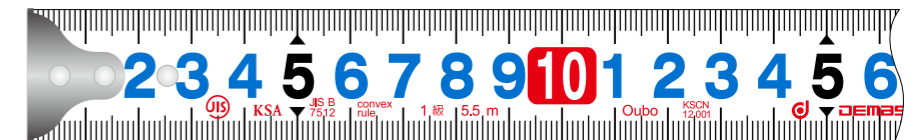

Metric JIS scale

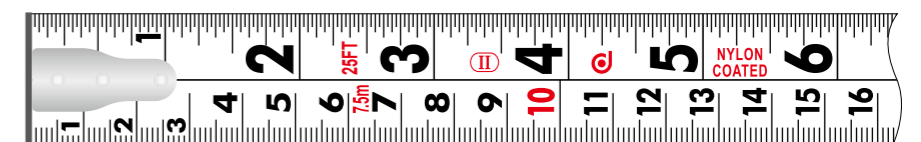
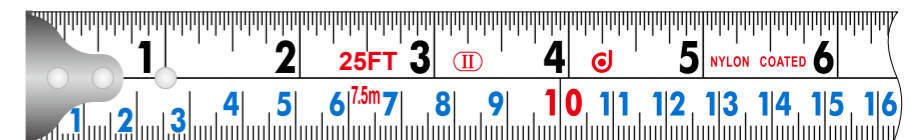

Metric / Inch scale

# Reference of end hook

## 1. End hook of pocket tape

A: EC-type hook

B: EC-type dual hook

C: EC-type magnet dual hook

D: General hook

E: General magnet hook

F: General dual hook

G: General magnet dual hook

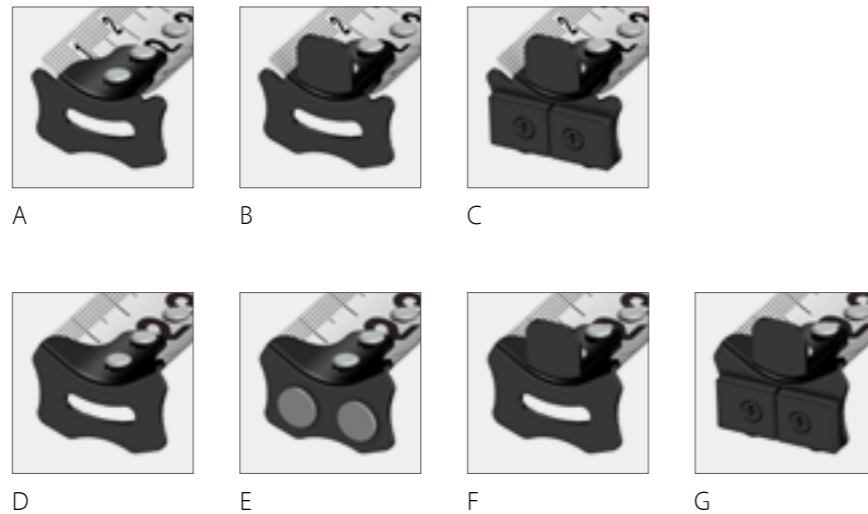





## 2. End hook of long steel tape and fiberglass tape

H: Pull ring





I: End hook with pull ring



Blade width 	EC-type hook	General hook	EC-type dual hook	General dual hook	General magnet hook	EC-type magnet dual hook	General magnet dual hook
16mm	•	•	-	-	•	-	-
19mm	•	•	•	•	•	•	•
22mm	•	•	•	•	•	•	•
25mm	•	•	•	•	•	•	•
27mm	•	•	•	•	•	•	•

Reference	EC-type hook	General hook	EC-type dual hook	General dual hook	General magnet hook	EC-type magnet dual hook	General magnet dual hook
 Metric MID scale	•	-	•	-	-	•	-
 Metric JIS scale	-	•	-	•	•	-	•
 Metric /Inch MID scale	-	•	-	•	•	-	•
 Metric /Inch scale	-	•	-	•	•	-	•
 Inch standard scale	-	•	-	•	•	-	•
 Inch easy-read scale	-	•	-	•	•	-	•
 Chi / Metric scale	-	•	-	•	•	-	•

# Blade stand-out

Blade width 	Horizontal stand-out 	Vertical stand-out 	Back side Vertical stand-out 
16mm	1.5m	2.1m	3m
19mm	1.8m	2.6m	3.5m
22mm	2m	3.1m	4.5m
25mm	2.3m	3.6m	5.8m
27mm	2.9m	4.6m	6.8m
19mm Dual hook	1.75m	2.55m	3.45m
22mm Dual hook	1.95m	3.05m	4.45m
25mm Dual hook	2.25m	3.55m	5.75m
27mm Dual hook	2.85m	4.55m	6.75m
19mm Magnet dual hook	1.7m	2.5m	3.4m
22mm Magnet dual hook	1.9m	3m	4.4m
25mm Magnet dual hook	2.2m	3.5m	5.7m
27mm Magnet dual hook	2.8m	4.5m	6.7m

# Blister card

Material is available in PVC or PET-G

Round style



Europe stand style



Hanging style



GG & FGG style



LWX & FWX style



Japan stand style



© OUBO 2015

All materials and illustrations included in this catalogue are the copyright of OUBO and can not be reprinted or duplicated without written permission.

OUBO reserves the right to amend the specifications to improve the products.

Designed in 2015

Design Team:

 **DEMASS**  
Physical design by DEMASS

 **SOHUI**  
Shape design by Sohui

 **Sunnydesign**  
Graphic design by Sunnydesign

